

RD-65

Remote Display



- **Highly Durable**– Powder coated mild steel enclosure (IP65) with wall mount swivel bracket or easy to install hanging rings. Adjustable sun visor included
- **Serial Port**– RS-232, RS-485 or current loop with selection to five protocols, three data formats and 8 types of baud rates
- **Display**– Double row ultra bright large 5", 6 Digit LED Display visible up to 150'
- **Displays up to 999,999 or down to -99,999**
- **Annunciator**– kg, lb, G (gross), N (net)

RD-65 Remote Display

Specifications

Enclosure:

Powder Coated, Mild Steel
Non Glare Lens

Operating Temperature:

-5° F to 122° F (-15° C to 50° C)

Display:

Display Type: 127 mm (5") 7 segment red LED display
Annunciators: kg, lb, G (gross), N (net)
Display Characters: 999,999 to -99,999

Communication Interface:

Serial Cable Length 10 m (32')
Serial Port: RS-232, RS-485 or Current Loop
Data Format: 8N1, 7E1 or 7O1
Baud Rate: 110, 300, 600, 1200, 2400, 4800, 9600 or 19200
Five Usable Input Protocols

Power:

Input: 120VAC , 60Hz
Transformer Output: 24VAC, 2 Amp (UL, Waterproof)
Current Draw: <1500mA
Fused: 2.0 amp

Shipping Specifications:

Weight: 20 kg (45 lb)
Package Dimensions:
464 mm x 448 mm x 999 mm (39.3" x 18.3" x 17.6")

Warranty:

One Year from Shipment

Product Code:

816965004638

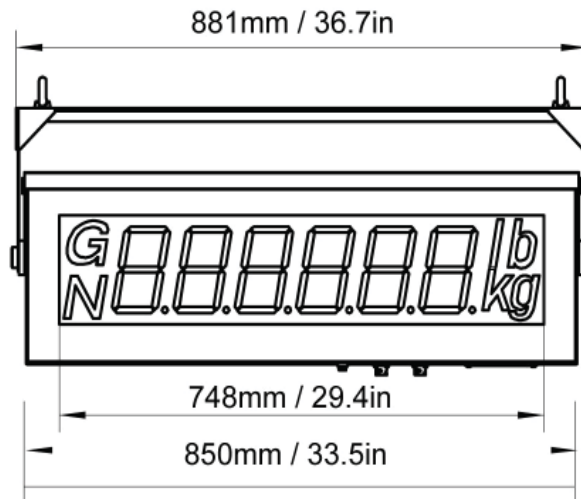
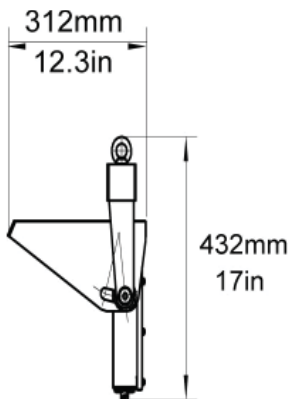

a division of Avery Weigh-Tronix, LLC



6/10

RD-65_L_500548.indd

AWT35-500548A

